



# Microtips

---

## TECHNOLOGY

Model No:13-043YDSBIA00-C

This module uses ROHS material

Approved By	

Tel: 1 (888) 499-8477

Fax: (407) 273-0771

E-mail: [mtusainfo@microtipsusa.com](mailto:mtusainfo@microtipsusa.com)

Web: [www.microtipsusa.com](http://www.microtipsusa.com)

## RECORD OF REVISION

Version	Revised Date	Page	Content
V1.0	2021/05/18	--	First Issued

## TABLE OF CONTENTS

No.	Content	Page
	TFT Module Specification .....	1
	TABLE OF CONTENTS .....	2
1.	GENERAL DESCRIPTION .....	4
2.	MECHANICAL SPECIFICATION .....	5
3.	PIN DESCRIPTION .....	6
4.	ABSOLUTE MAXIMUM RATINGS .....	8
5.	BLOCK DIAGRAM .....	9
6.	RELATIONSHIP BETWEEN DISPLAYED COLOR AND INPUT .....	10
7.	ELECTRICAL CHARACTERISTICS .....	11
8.	PROJECTED CAPACITIVE TOUCH PANEL .....	18
9.	OPTICAL CHARACTERISTICS .....	24
10.	RELIABILITY.....	27
11.	PRECAUTION RELATING PRODUCT HANDLING .....	32

## 1. GENERAL DESCRIPTION

### 1.1 Description

The specification is model 13-043YDSBIA00-C is a color active matrix thin film transistor (TFT) liquid crystal display (LCD) that uses amorphous silicon TFT as a switching device. This model is composed of a TFT LCD panel, a driving circuit, a backlight system and projected capacitive touch panel. This TFT LCD has a 4.3 (16:9) inch diagonally measured active display area with WQVGA (480 horizontal by 272 vertical pixels) resolution.

### 1.2 Features:

No.	Item	Specification	Unit
1	Panel Size	4.3"	Inch
2	Number of Pixels	480 (W) x RGB x 272 (H)	Pixels
3	Active Area	95.04 (W) x 53.856 (H)	mm
4	Pixel Pitch	0.198 (W) x 0.198(H)	mm
5	Outline Dimension	105.5 (W) x 67.2 (H) x 4.55 (T)	mm
6	Number of Colors	16.7M	- -
7	Display Mode	IPS / Normally Black / Transmissive	- -
8	View Direction	Free direction	
9	Display Format	RGB vertical stripe	- -
10	Surface Treatment	Clear (7H)	- -
11	Contrast Ratio	800 (Typ.)	- -
12	Luminance (cd/m <sup>2</sup> )	500 (Typ.)	cd/m <sup>2</sup>
13	Interface	RGB 24bit Interface	- -
14	Backlight	White LED	- -
15	Driver IC	SC7283	- -
16	Operation Temperature	-20 ~ 70	°C
17	Storage Temperature	-30 ~ 80	°C
18	Weight	TBD	g

## 2. MECHANICAL SPECIFICATION

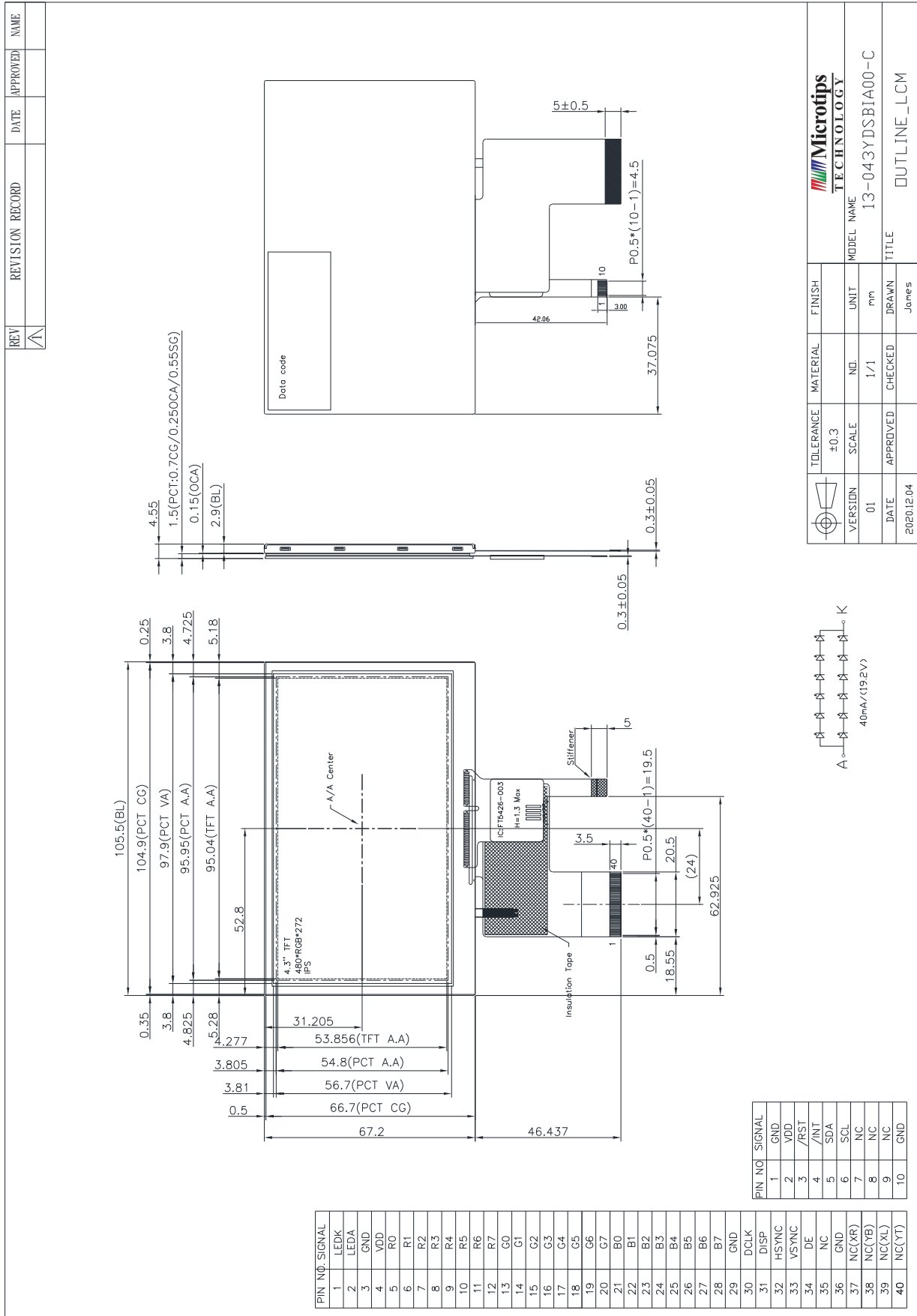

### 3. PIN DESCRIPTION

Pin No.	Symbol	I/O	Function	Note
1	VLED-	P	Power for LED backlight cathode	
2	VLED+	P	Power for LED backlight anode	
3	GND	P	Power Ground	
4	VDD	P	Power Supply	
5	R0	I	Red data signal (LSB)	
6	R1	I	Red data signal	
7	R2	I	Red data signal	
8	R3	I	Red data signal	
9	R4	I	Red data signal	
10	R5	I	Red data signal	
11	R6	I	Red data signal	
12	R7	I	Red data signal (MSB)	
13	G0	I	Green data signal (LSB)	
14	G1	I	Green data signal	
15	G2	I	Green data signal	
16	G3	I	Green data signal	
17	G4	I	Green data signal	
18	G5	I	Green data signal	
19	G6	I	Green data signal	
20	G7	I	Green data signal (MSB)	
21	B0	I	Blue data signal (LSB)	
22	B1	I	Blue data signal	
23	B2	I	Blue data signal	
24	B3	I	Blue data signal	
25	B4	I	Blue data signal	
26	B5	I	Blue data signal	
27	B6	I	Blue data signal	
28	B7	I	Blue data signal (MSB)	
29	DGND	P	Digital ground	
30	DCLK	I	Pixel clock	
31	DISP	I	Display on/ off	
32	HSYNC	I	Horizontal sync signal	
33	VSYNC	I	Vertical sync signal	
34	DE	I	Data Enable signal	

35	NC	-	No Connect	
36	GND	P	Power Ground	
37	NC	-	No connect	
38	NC	-	No connect	
39	NC	-	No connect	
40	NC	-	No connect	

**4. ABSOLUTE MAXIMUM RATINGS**

**4.1 Electrical Absolute Rating**

**4.1.1 TFT LCD Module**

Item	Symbol	Values		Unit	Note
		Min	Max.		
Power supply voltage	VDD	-0.3	4.0	V	

**4.1.2 Environment Absolute Rating**

Item	Symbol	Values			Unit	Note
		Min	Typ	Max.		
Operating Temperature	Topa	-20		70	°C	Ambient temperature
Storage Temperature	Tstg	-30		80	°C	



5. BLOCK DIAGRAM

5.1 TFT LCD Module

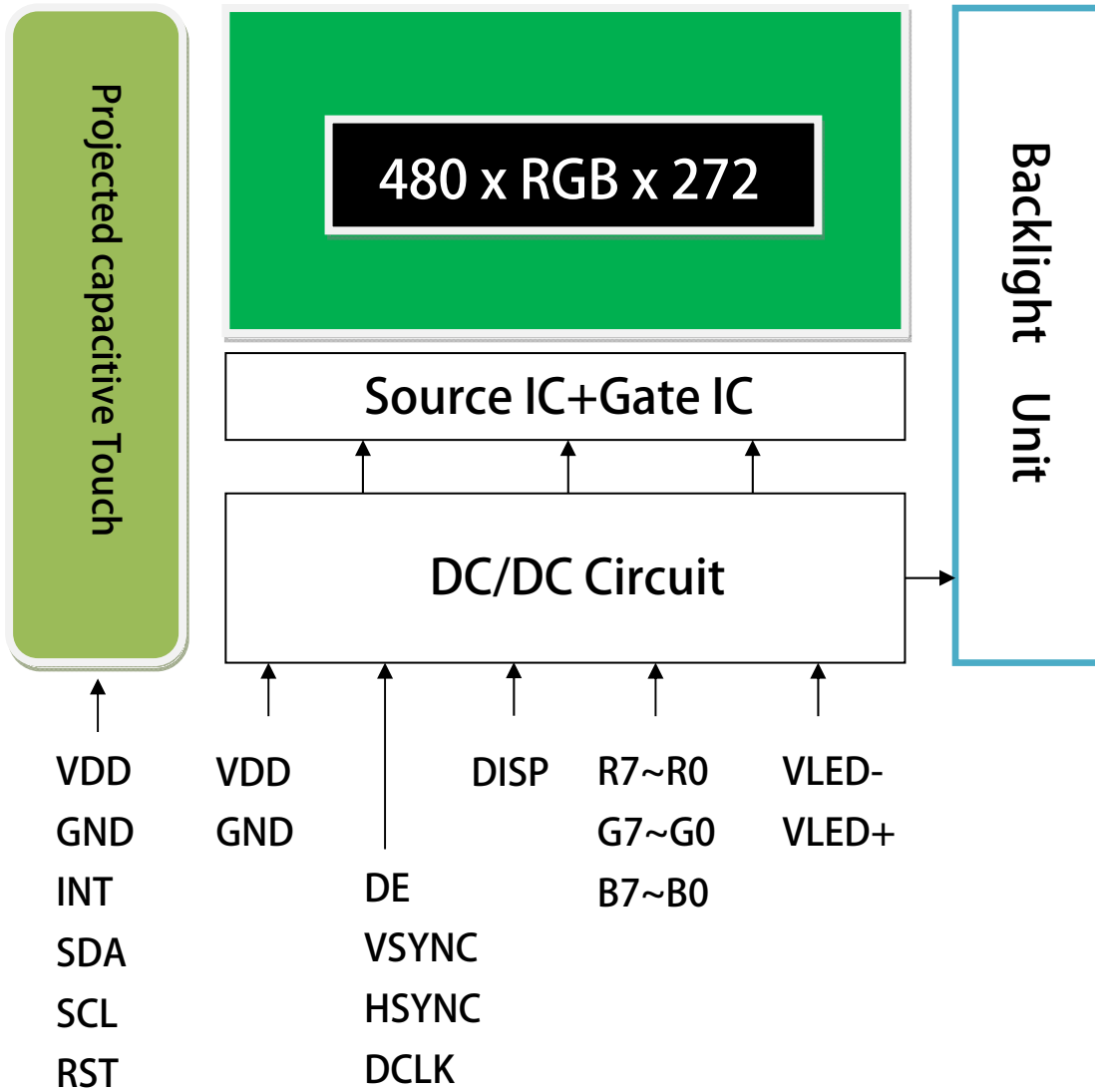

## 6. Relationship Between Displayed Color and Input

### 6.1 8 bit

	Color & Gray Scale	Data Signal																							
		R7	R6	R5	R4	R3	R2	R1	R0	G7	G6	G5	G4	G3	G2	G1	G0	B7	B6	B5	B4	B3	B2	B1	B0
Basic Color	Black	0	0	0	0	0	0	0	0	0	0	0	0	0	0	0	0	0	0	0	0	0	0	0	0
	Red	1	1	1	1	1	1	1	1	0	0	0	0	0	0	0	0	0	0	0	0	0	0	0	0
	Green	0	0	0	0	0	0	0	0	1	1	1	1	1	1	1	1	0	0	0	0	0	0	0	0
	Blue	0	0	0	0	0	0	0	0	0	0	0	0	0	0	0	0	1	1	1	1	1	1	1	1
	Cyan	0	0	0	0	0	0	0	0	1	1	1	1	1	1	1	1	1	1	1	1	1	1	1	1
	Magenta	1	1	1	1	1	1	1	1	0	0	0	0	0	0	0	0	1	1	1	1	1	1	1	1
	Yellow	1	1	1	1	1	1	1	1	1	1	1	1	1	1	1	1	0	0	0	0	0	0	0	0
	White	1	1	1	1	1	1	1	1	1	1	1	1	1	1	1	1	1	1	1	1	1	1	1	1
Red	Black	0	0	0	0	0	0	0	0	0	0	0	0	0	0	0	0	0	0	0	0	0	0	0	
	Red(1)	0	0	0	0	0	0	0	1	0	0	0	0	0	0	0	0	0	0	0	0	0	0	0	
	Red(2)	0	0	0	0	0	0	1	0	0	0	0	0	0	0	0	0	0	0	0	0	0	0	0	
	:	:	:	:	:	:	:	:	:	:	:	:	:	:	:	:	:	:	:	:	:	:	:	:	
	Red(127)	0	1	1	1	1	1	1	1	0	0	0	0	0	0	0	0	0	0	0	0	0	0	0	
	:	:	:	:	:	:	:	:	:	:	:	:	:	:	:	:	:	:	:	:	:	:	:	:	
	Red(254)	1	1	1	1	1	1	1	0	0	0	0	0	0	0	0	0	0	0	0	0	0	0	0	
	Red(255)	1	1	1	1	1	1	1	1	0	0	0	0	0	0	0	0	0	0	0	0	0	0	0	
Green	Black	0	0	0	0	0	0	0	0	0	0	0	0	0	0	0	0	0	0	0	0	0	0	0	
	Green(1)	0	0	0	0	0	0	0	0	0	0	0	0	0	0	1	0	0	0	0	0	0	0	0	
	Green(2)	0	0	0	0	0	0	0	0	0	0	0	0	0	1	0	0	0	0	0	0	0	0	0	
	:	:	:	:	:	:	:	:	:	:	:	:	:	:	:	:	:	:	:	:	:	:	:	:	
	Green(127)	0	0	0	0	0	0	0	0	0	1	1	1	1	1	1	1	0	0	0	0	0	0	0	
	:	:	:	:	:	:	:	:	:	:	:	:	:	:	:	:	:	:	:	:	:	:	:	:	
	Green(254)	0	0	0	0	0	0	0	0	1	1	1	1	1	1	1	0	0	0	0	0	0	0	0	
	Green(255)	0	0	0	0	0	0	0	0	1	1	1	1	1	1	1	0	0	0	0	0	0	0	0	
Blue	Black	0	0	0	0	0	0	0	0	0	0	0	0	0	0	0	0	0	0	0	0	0	0	0	
	Blue(1)	0	0	0	0	0	0	0	0	0	0	0	0	0	0	0	0	0	0	0	0	0	0	1	
	Blue(2)	0	0	0	0	0	0	0	0	0	0	0	0	0	0	0	0	0	0	0	0	0	1	0	
	:	:	:	:	:	:	:	:	:	:	:	:	:	:	:	:	:	:	:	:	:	:	:	:	
	Blue(127)	0	0	0	0	0	0	0	0	0	0	0	0	0	0	0	0	1	1	1	1	1	1	1	
	:	:	:	:	:	:	:	:	:	:	:	:	:	:	:	:	:	:	:	:	:	:	:	:	
	Blue(254)	0	0	0	0	0	0	0	0	0	0	0	0	0	0	0	1	1	1	1	1	1	1	0	
	Blue(255)	0	0	0	0	0	0	0	0	0	0	0	0	0	0	0	1	1	1	1	1	1	1	1	

0 : Low level voltage, 1 :High level voltage

Each basic color can be displayed in 256 gray scales from 8 bit data signals. With the combination of total 24 bit data signals, the 16,777,216-color display can be achieved on the screen.

## 7. ELECTRICAL CHARACTERISTICS

### 7.1 TFT LCD Module

Item	Symbol	Value			Unit	Note
		Min.	Typ.	Max.		
Power supply voltage	VDD	3.0	3.3	3.6	V	
Input Voltage for logic	H Level	VIH	0.7xVDD	-	VDD	V
	L Level	VIL	0	-	0.3xVDD	V
Digital Current	IDD	-	23	30	mA	Note1

Note 1: frame =60Hz, Ta=25°C, Display pattern: white pattern

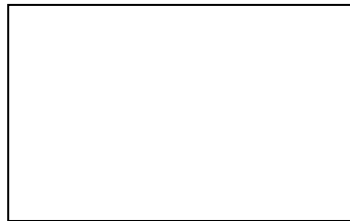

### 7.2 Backlight Unit

Item	Symbol	Value			Unit	Condition
		Min.	Typ.	Max.		
LED Voltage	VL	(18)	(19.2)	(20.4)	V	
LED Current	If	-	40	-	mA	6S2P
Power Consumption	PBL	-	768	-	mW	
LED Life Time (25°C)	-	(50000)	-	-	hr	(1)

Note (1): The “LED life time” is defined as the module brightness decrease to 50% original brightness that the ambient temperature is 25°C 60% RH.

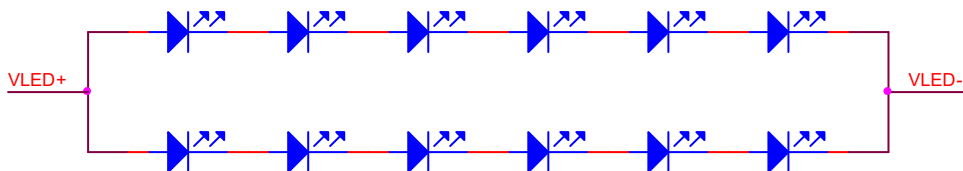

## 7.3 INTERFACE SPECIFICATIONS

### 7.3.1 Input Timing Table

Item	Symbol	Min.	Typ.	Max.	Unit
DOTCLK Frequency	Fclk	8	9	12	MHz
DOTCLK Period	Tclk	83	111	125	ns
Horizontal Back Porch	Thbp	3	43	43	DCLK
Horizontal Front Porch	Thfp	2	8	75	DCLK
Horizontal Pulse width	Thw	2	4	43	DCLK
Horizontal Display Area	Thdisp	-	480	-	DCLK
Horizontal Period	Th	485	531	598	DCLK
Vertical Back Porch	Tvbp	2	12	12	HSYNC
Vertical Front Porch	Tvfp	2	8	37	HSYNC
Vertical Pulse width	Tvw	2	4	12	HSYNC
Vertical Display	Tvdisp	-	272	-	HSYNC
Vertical Cycle	Tv	276	292	321	HSYNC

Note: It is necessary to keep Tvbp =12 and Thbp =43 in sync mode. DE mode is unnecessary to keep it.

RGB Mode Selection Table	DCLK	HSYNC	VSYNC	DE
SYNC - DE Mode	Input	Input	Input	Input
SYNC Mode	Input	Input	Input	GND
DE Mode	Input	GND	GND	Input

Note: "Input" means these signals are driven by host side.

### 7.3.2 SYNC Mode

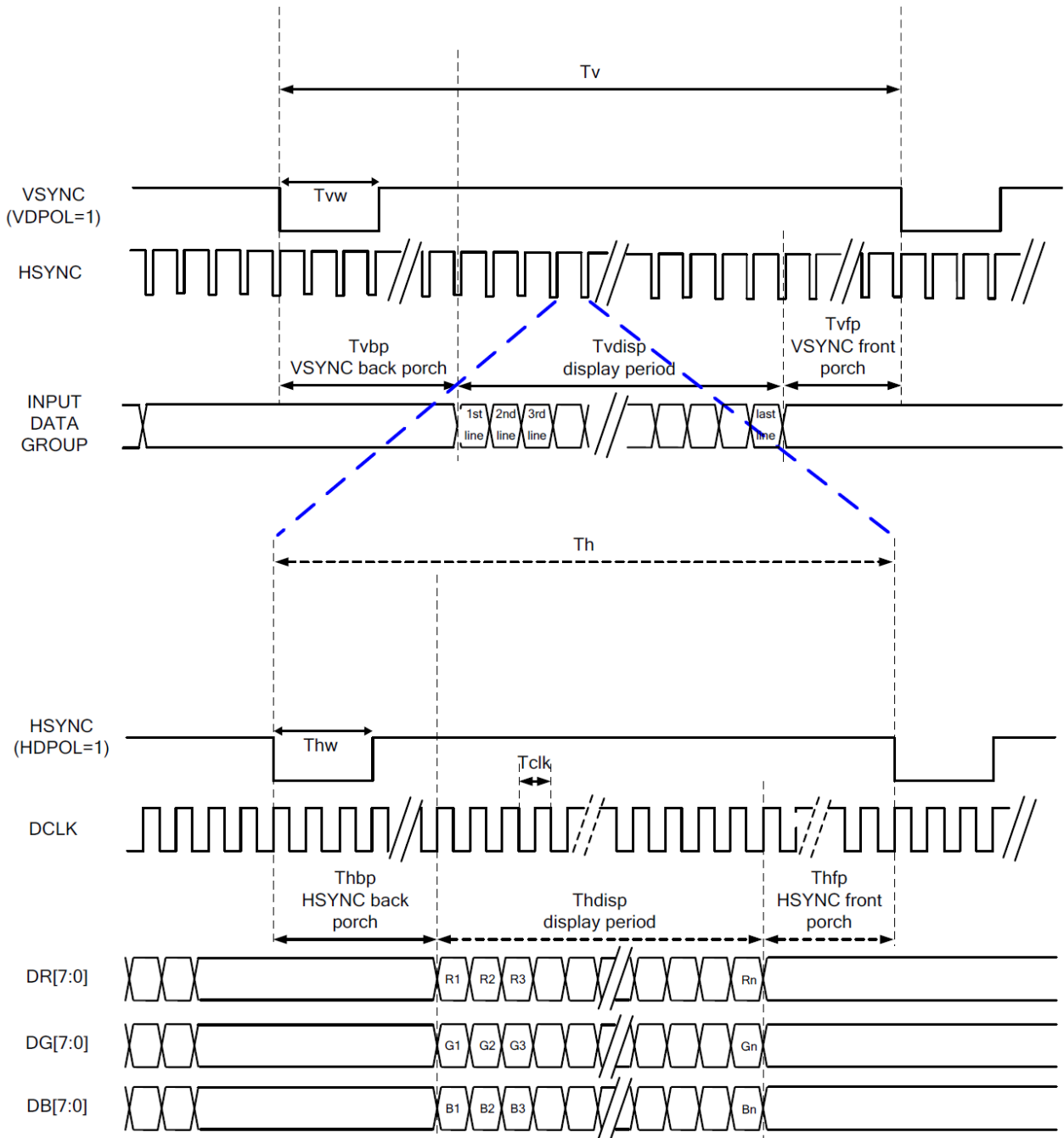

### 7.3.3 SYNC-DE Mode

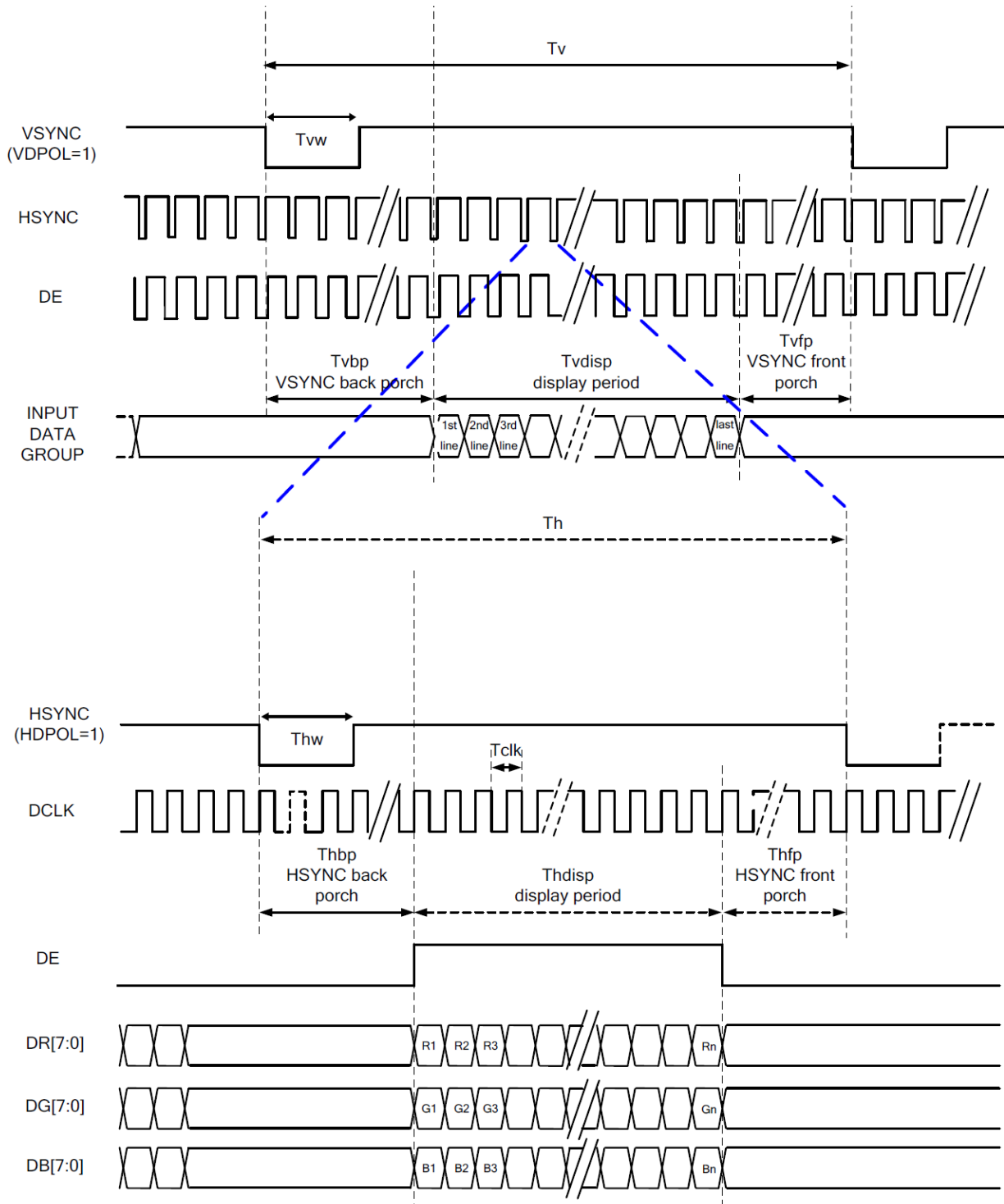

### 7.3.4 DE Mode

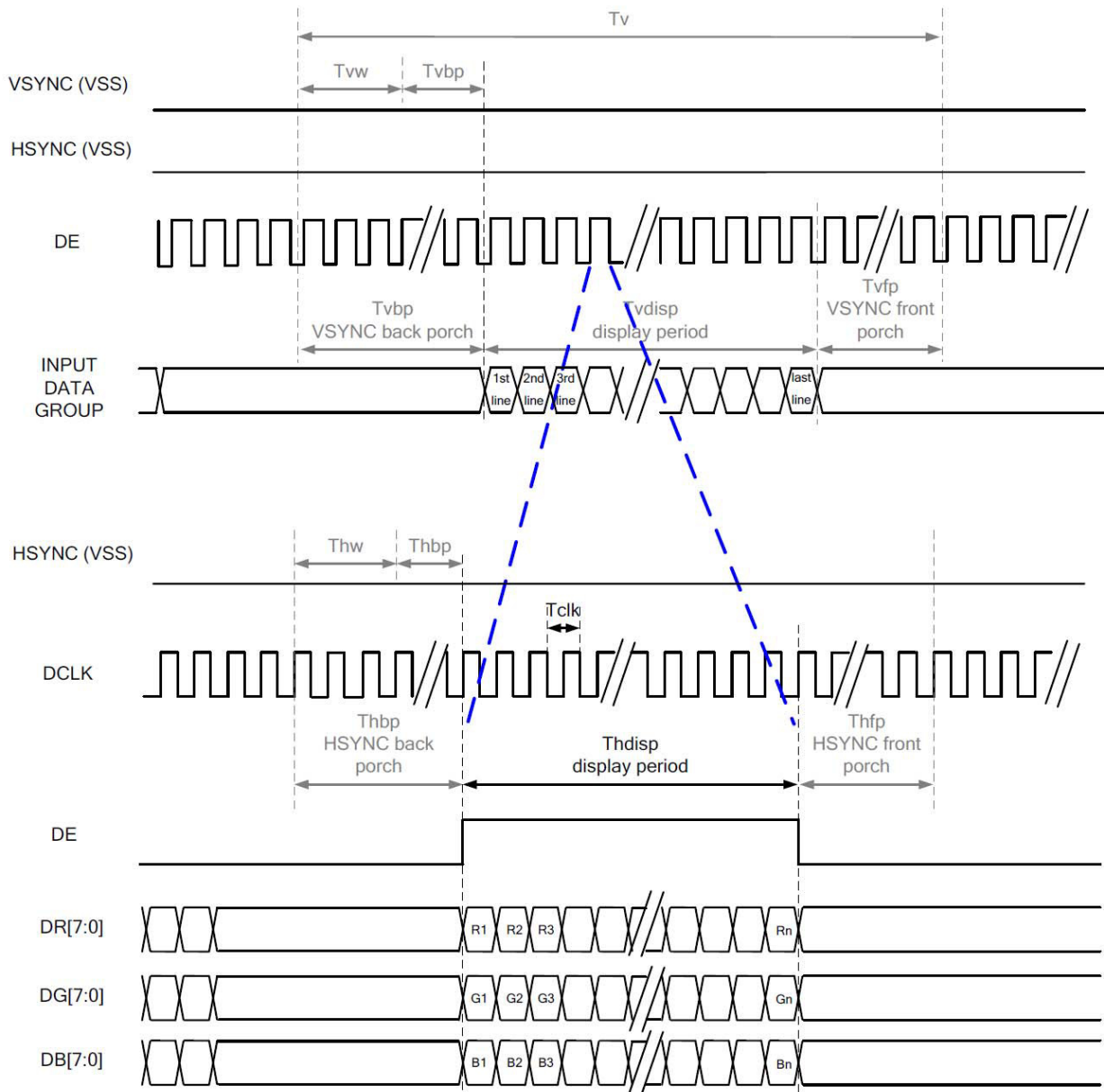

### 7.4 SYSTEM BUS TIMING FOR RGB INTERFACE

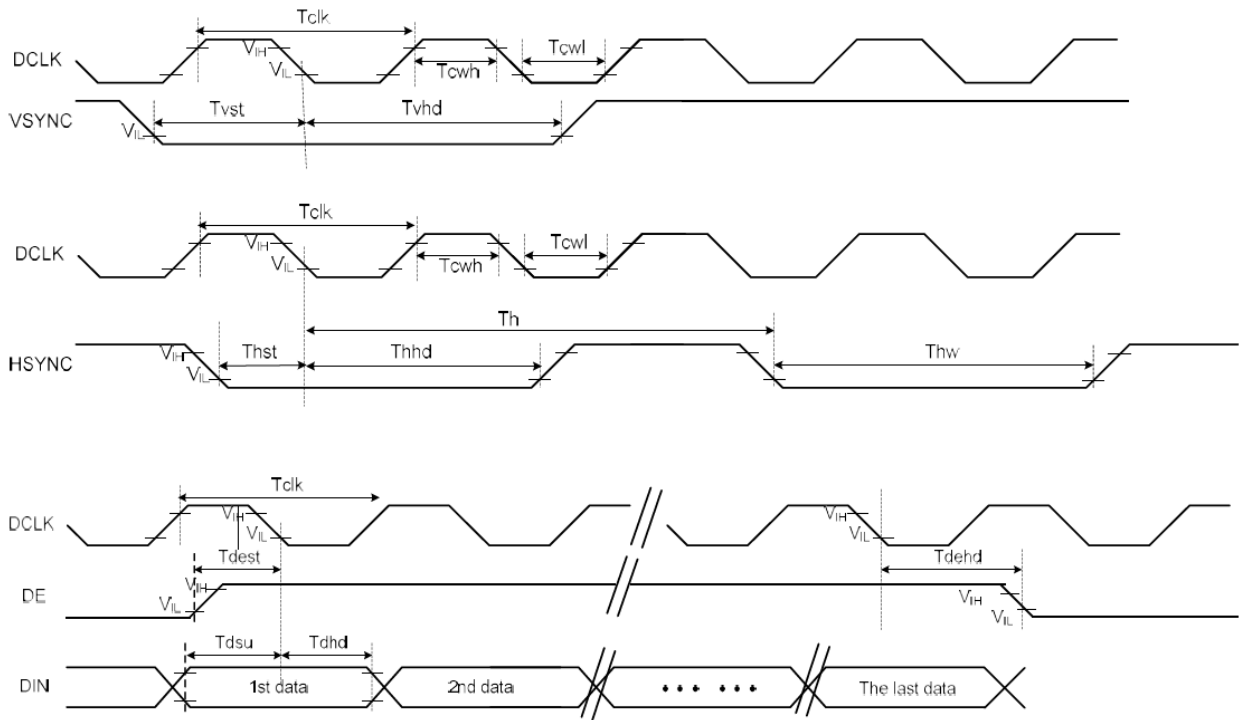

Item	Symbol	Min.	Typ.	Max.	Unit	Conditions
CLK Pulse Duty	Tcw	40	50	60	%	
HSYNC Width	Thw	2	-	-	DCLK	
HSYNC Period	Th	55	60	65	us	
VSYNC Setup Time	Tvst	12	-	-	ns	
VSYNC Hold Time	Tvhd	12	-	-	ns	
HSYNC Setup Time	Thst	12	-	-	ns	
HSYNC Hold Time	Thhd	12	-	-	ns	
Data Setup Time	Tdsu	12	-	-	ns	
Data Hold Time	Tdhd	12	-	-	ns	
DE Setup Time	Tdest	12	-	-	ns	
DE Hold Time	Tdehd	12	-	-	ns	



### 7.5 POWER ON / OFF SEQUENCE

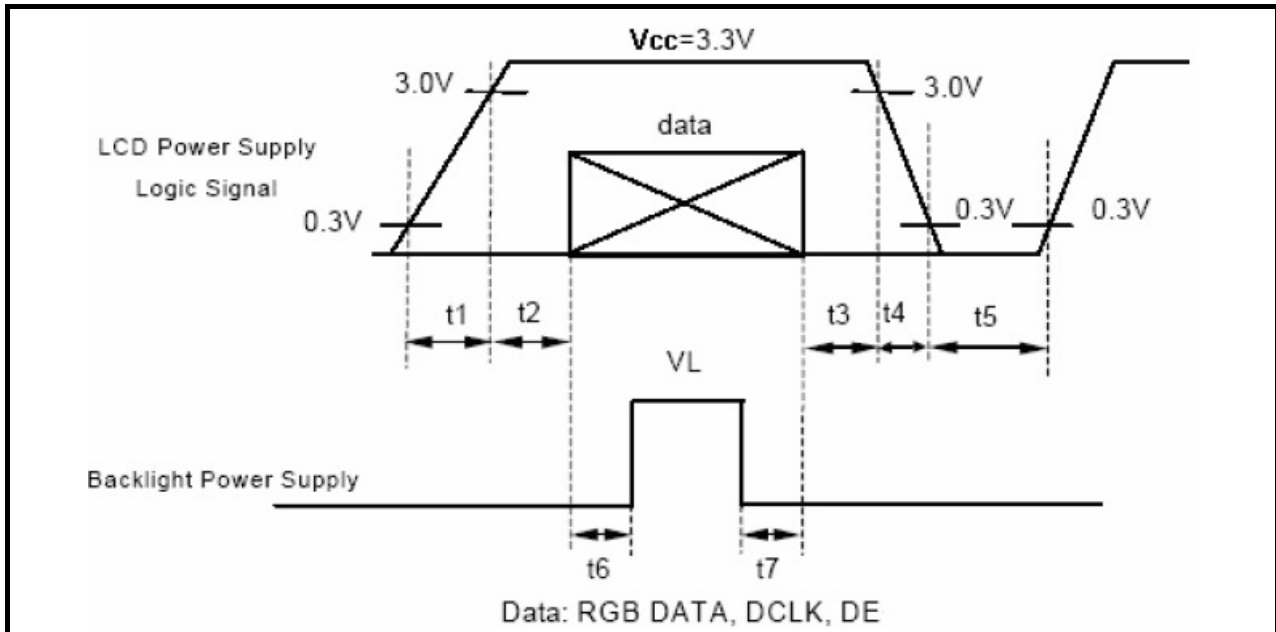

$t1 \leq 10\text{ms} : 1 \text{ sec} \leq t5$   
 $20\text{ms} \leq t2 : 250\text{ms} \leq t6$   
 $80\text{ms} < t3 : 200\text{ms} \leq t7$   
 $0 < t4 \leq 10\text{ms}$

## 8. PROJECTED CAPACITIVE TOUCH PANEL

### 8.1 Main Feature

Item	Specification	Unit
Screen Size	4.3 inch	Diagonal
Type	Transparent Type Projected Capacitive	--
Input Mode	Human's Finger	--
Finger	5	--
Interface	I2C	--
Cover glass pencil-hardness	7H	--
Response time	25	ms
Driver IC	FT5426	

### 8.2 Pin Assignments and Definitions

Item	Name	I/O	Unit
1	GND	P	Power ground
2	VDD	P	Power; VDD =3.3V(typ.)
3	/RST	I	Reset, Active low
4	INT	O	Interrupt, Active low
5	SDA	I/O	Serial data
6	SCL	I	Serial Clock
7	NC	-	No connection
8	NC	-	No connection
9	NC	-	No connection
10	GND	P	Power ground

### 8.3 ELECTRICAL CHARACTERISTICS

Communication protocol: I2C

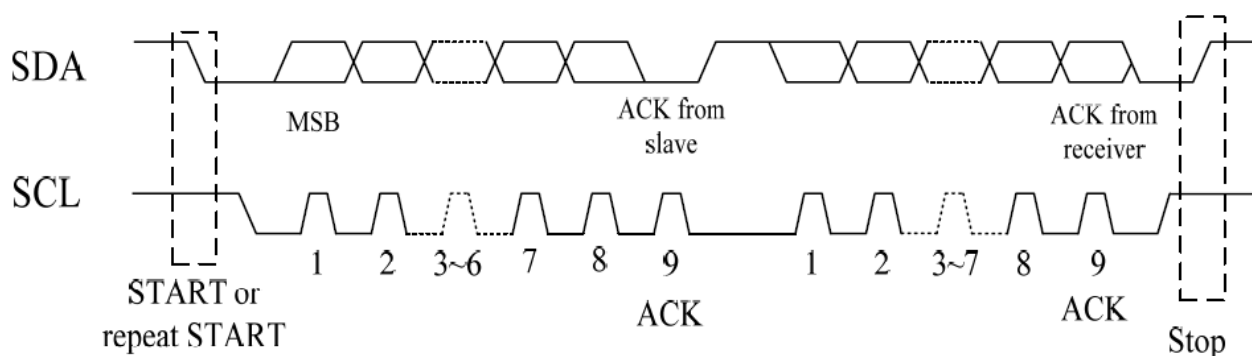

## 8.4 Interface and Data Format

### 8.4.1 Default I2C Address

The default I2C Address of FT5426 is 0x70 (8-bit address)

### 8.4.2 I2C master write, slave read

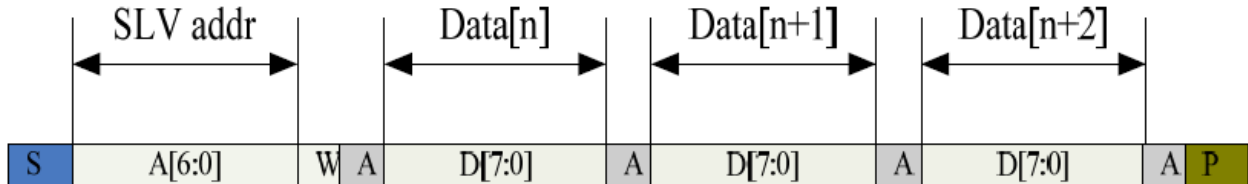

### 8.4.3 I2C master read, slave write

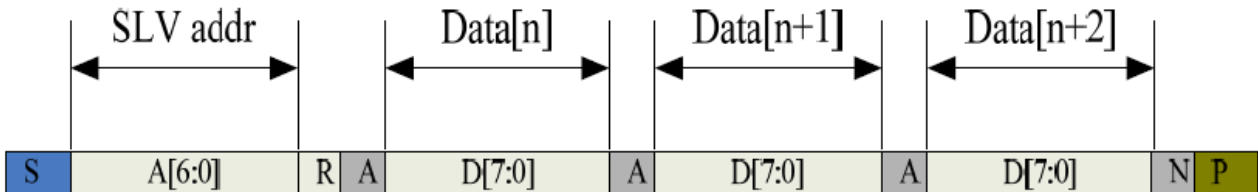

Mnemonics	Description
S	I2C Start or I2C Restart
A[6:0]	Slave address A[6:4]: 3'b011 A[3:0]: data bits are identical to those of I2CCON[7:4] register.
W	1'b0: Write
R	1'b1: Read
A(N)	ACK(NACK)
P	STOP: the indication of the end of a packet (if this bit is missing, S will indicate the end of the current packet and the beginning of the next packet)

## 8.5 Register Definitions

Address	Name	Bit7	Bit6	Bit5	Bit4	Bit3	Bit2	Bit1	Bit0	Host Access
00h	DEVIDE_MODE	Device Mode[2:0]								RW
01h	GEST_ID	Gesture ID[7:0]								R
02h	TD_STATUS					Number of touch points[3:0]				R
03h	TOUCH1_XH	1 <sup>st</sup> Event Flag				1 <sup>st</sup> Touch X Position[11:8]				R
04h	TOUCH1_XL	1 <sup>st</sup> Touch X Position[7:0]								R
05h	TOUCH1_YH	1 <sup>st</sup> Touch ID[3:0]				1 <sup>st</sup> Touch Y Position[11:8]				R
06h	TOUCH1_YL	1 <sup>st</sup> Touch Y Position[7:0]								R
07h										
08h										
09h	TOUCH2_XH	2 <sup>nd</sup> Event Flag				2 <sup>nd</sup> Touch X Position[11:8]				R
0Ah	TOUCH2_XL	2 <sup>nd</sup> touch X Position[7:0]								R
0Bh	TOUCH2_YH	2 <sup>nd</sup> Touch ID[3:0]				2 <sup>nd</sup> Touch Y Position[11:8]				R
0Ch	TOUCH2_YL	2 <sup>nd</sup> Touch Y Position[7:0]								R
0Dh										R
0Eh										R
0Fh	TOUCH3_XH	3 <sup>rd</sup> Event Flag				3 <sup>rd</sup> Touch X Position[11:8]				R
10h	TOUCH3_XL	3 <sup>rd</sup> Touch X Position[7:0]								R
11h	TOUCH3_YH	3 <sup>rd</sup> Touch ID[3:0]				3 <sup>rd</sup> Touch Y Position[11:8]				R
12h	TOUCH3_YL	3 <sup>rd</sup> Touch Y Position[7:0]								R
13h										R
14h										R

15h	TOUCH4_XH	4 <sup>th</sup> Event Flag		4 <sup>th</sup> Touch X Position[11:8]	R
16h	TOUCH4_XL	4 <sup>th</sup> Touch X Position[7:0]			R
17h	TOUCH4_YH	4 <sup>th</sup> Touch ID[3:0]		4 <sup>th</sup> Touch Y Position[11:8]	R
18h	TOUCH4_YL	4 <sup>th</sup> Touch Y Position[7:0]			R
19h					R
1Ah					R
1Bh	TOUCH5_XH	5 <sup>th</sup> Event Flag		5 <sup>th</sup> Touch X Position[11:8]	R
1Ch	TOUCH5_XL	5 <sup>th</sup> Touch X Position[7:0]			R
1Dh	TOUCH5_YH	5 <sup>th</sup> Touch ID[3:0]		5 <sup>th</sup> Touch Y Position[11:8]	R
1Eh	TOUCH5_YL	5 <sup>th</sup> Touch Y Position[7:0]			R
1Fh					R
20h					R
21h	TOUCH6_XH	6 <sup>th</sup> Event Flag		6 <sup>th</sup> Touch X Position[11:8]	
22h	TOUCH6_XL	6 <sup>th</sup> Touch X Position[7:0]			
23h	TOUCH6_YH	6 <sup>th</sup> Touch ID[3:0]		6 <sup>th</sup> Touch Y Position[11:8]	
24h	TOUCH6_YL	6 <sup>th</sup> Touch Y Position[7:0]			
25h					
26h					
27h	TOUCH7_XH	7 <sup>th</sup> Event Flag		7 <sup>th</sup> Touch X Position[11:8]	
28h	TOUCH7_XL	7 <sup>th</sup> Touch X Position[7:0]			
29h	TOUCH7_YH	7 <sup>th</sup> Touch ID[3:0]		7 <sup>th</sup> Touch Y Position[11:8]	
2Ah	TOUCH7_YL	7 <sup>th</sup> Touch Y Position[7:0]			
2Bh					
2Ch					
2Dh	TOUCH8_XH	8 <sup>th</sup> Event Flag		8 <sup>th</sup> Touch X Position[11:8]	
2Eh	TOUCH8_XL	8 <sup>th</sup> Touch X Position[7:0]			
2Fh	TOUCH8_YH	8 <sup>th</sup> Touch ID[3:0]		8 <sup>th</sup> Touch Y Position[11:8]	
30h	TOUCH8_YL	8 <sup>th</sup> Touch Y Position[7:0]			
31h					
32h					



33h	TOUCH9_XH	9 <sup>th</sup> Event Flag		9 <sup>th</sup> Touch X Position[11:8]	
34h	TOUCH9_XL	9 <sup>th</sup> Touch X Position[7:0]			
35h	TOUCH9_YH	9 <sup>th</sup> Touch ID[3:0]		9 <sup>th</sup> Touch Y Position[11:8]	
36h	TOUCH9_YL	9 <sup>th</sup> Touch Y Position[7:0]			
37h					
38h					
39h	TOUCH10_XH	10 <sup>th</sup> Event Flag		10 <sup>th</sup> Touch X Position[11:8]	
3Ah	TOUCH10_XL	10 <sup>th</sup> Touch X Position[7:0]			
3Bh	TOUCH10_YH	10 <sup>th</sup> Touch ID[3:0]		10 <sup>th</sup> Touch Y Position[11:8]	
3Ch	TOUCH10_YL	10 <sup>th</sup> Touch Y Position[7:0]			
3Dh					
3Eh					
3Fh	Reserved				
...	...				
7Fh	Reserved				
80h	ID_G_THGROUP	valid touching detect threshold.			R/W
81h	ID_G_THPEAK	valid touching peak detect threshold.			R/W
82h	ID_G_THCAL	the threshold when calculating the focus of touching.			R/W
83h	ID_G_THWATER	the threshold when there is surface water.			R/W
84h	ID_G_THTEMP	the threshold of temperature compensation.			R/W
85h					R/W
86h	ID_G_CTRL			Power control mode[1:0]	R/W
87h	ID_G_TIME_ENTER_MONITOR	The timer of entering monitor status			R/W
88h	ID_G_PERIODACTIVE			Period Active[3:0]	R/W
89h	ID_G_PERIODMONITOR	The timer of entering idle while in monitor status			R/W
8Ah					R/W
8Bh					R/W
8Ch					R/W
8Dh					R/W
8Eh					R/W
8Fh					R/W
90h					R/W

91h			R/W
92h			R/W
93h			R/W
94h			R/W
95h			R/W
96h			R/W
97h			R/W
98h			R/W
99h			R/W
9Ah			R/W
9Bh			R/W
9Ch			R/W
9Dh			R/W
9Eh			R/W
9Fh			R/W
A0h	ID_G_AUTO_CLB_MODE	auto calibration mode	R/W
A1h	ID_G_LIB_VERSION_H	Firmware Library Version H byte	R
A2h	ID_G_LIB_VERSION_L	Firmware Library Version L byte	R
A3h	ID_G_CIPHER	Chip vendor ID	R
A4h	ID_G_MODE	the interrupt status to host	R
A5h	ID_G_PMODE	Power Consume Mode	
A6h	ID_G_FIRMID	Firmware ID	R
A7h	ID_G_STATE	Running State	
A8h	ID_G_FT5201ID	CTPM Vendor ID	R
A9h	ID_G_ERR	Error Code	R
AAh	ID_G_CLB	Configure TP module during calibration in Test Mode	R/W
ABh			R/W
ACH			R/W
ADh			R/W
AEh	ID_G_B_AREA_TH	The threshold of big area	R/W
AFh			R/W
...	...		
FDh	Reserved		
FEh	LOG_MSG_CNT	The log MSG count	R
FFh	LOG_CUR_CHA	Current character of log message, will point to the next character when one character is read.	R

## 9. OPTICAL CHARACTERISTICS

Item	Symbol	Condition	Min.	Typ.	Max.	Unit
Brightness	--	Note1, Note 3, ( $\theta = 0^\circ$ ; Normal Viewing Angle)	400	500	--	cd/m <sup>2</sup>
Uniformity	B-uni		70	75	-	%
Contrast Ratio	CR		600	800	--	--
Response Time	Tr+Tf		--	30	40	ms
Color Chromaticity	White	Wx	0.260	0.310	0.360	--
		Wy	0.280	0.330	0.380	--
View angle	Horizontal	$\theta_{x+}$	70	80	--	
		$\theta_{x-}$	70	80	--	
	Vertical	$\theta_{Y+}$	70	80	--	
		$\theta_{Y-}$	70	80	--	

Note : The following optical specifications shall be measured in a darkroom or equivalent state (ambient luminance  $\leq 1$  lux, and at room temperature). The operation temperature is  $25^\circ\text{C} \pm 2^\circ\text{C}$ . The measurement method is shown in Note1.

Note1: The method of optical measurement:

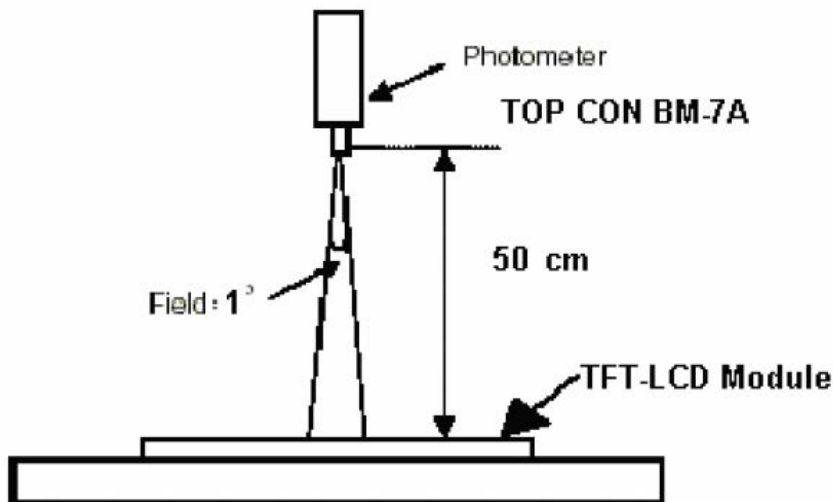

Note2: Measured at the center area of the panel and at the viewing angle of the  $\theta_x = \theta_y = 0^\circ$

Note3: Definition of Contrast Ratio (CR):

CR = Luminance with all pixels in white state  $\div$  Luminance with all pixels in Black state



**Note 4: Definition of Viewing Angle:**

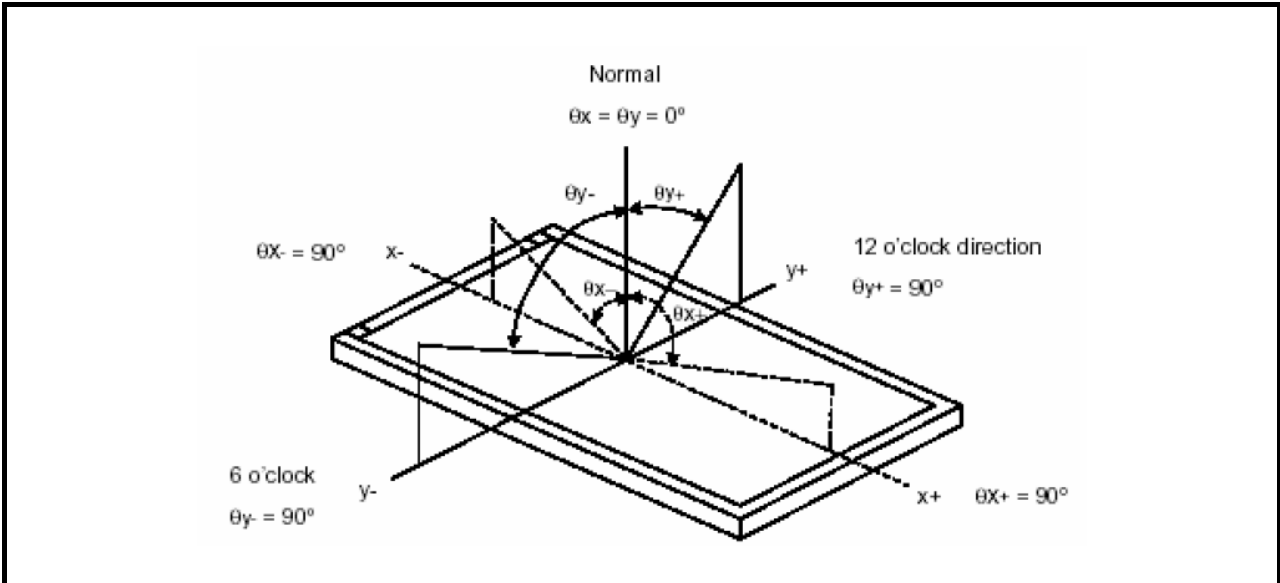

**Note 5: Definition of Brightness Uniformity (B-uni):**

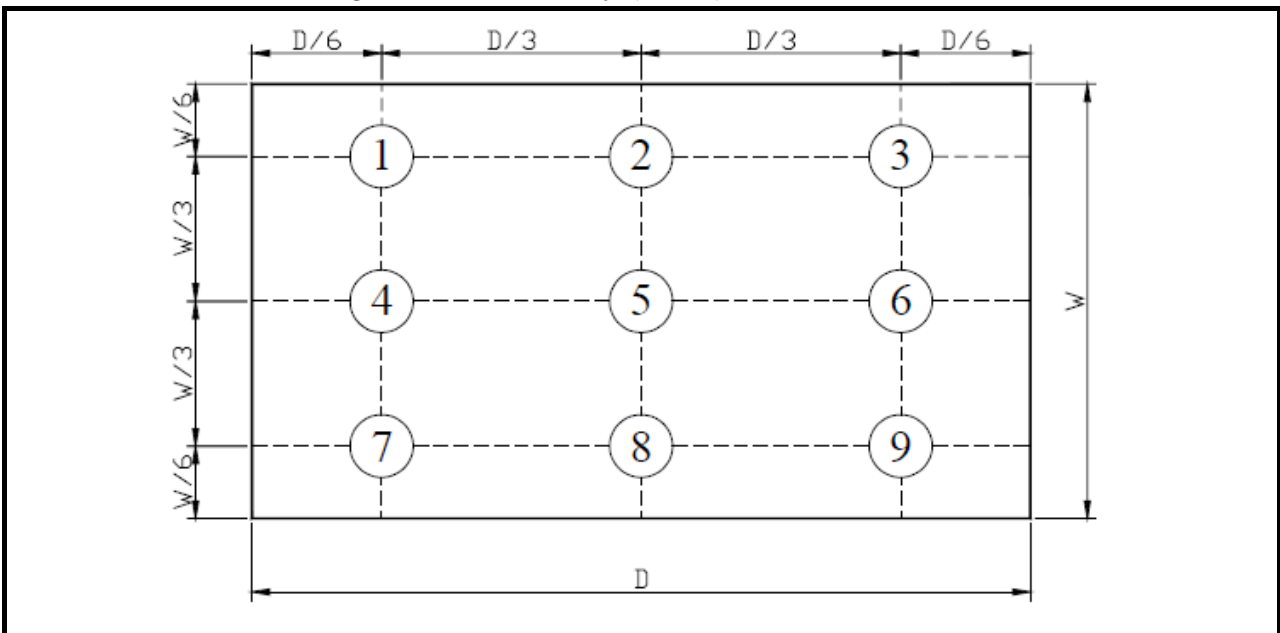

$B\text{-uni} = (\text{Minimum luminance of 9 points} \div \text{Maximum luminance of 9 points}) \times 100\%$

**Note 6: Definition of Response Time:**

The Response Time is set initially by defining the “Rising Time (Tr)” and the “Falling Time (Tf)” respectively. Tr and Tf are defined as following figure

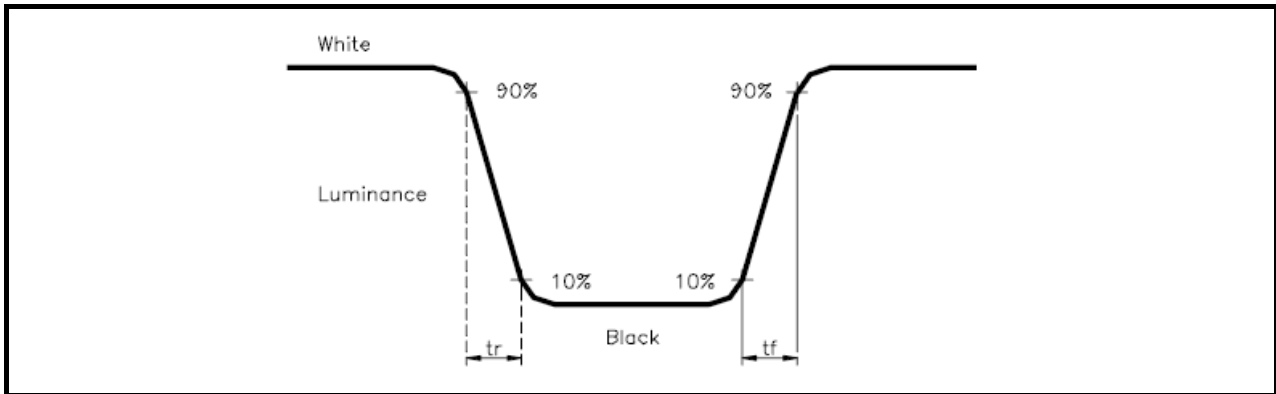

**Note 7: Definition of Chromaticity:**

The color coordinates (Wx,Wy),(Rx,Ry),(Gx,Gy),and (Bx,By) are obtained with all pixels in the viewing field at white, red, green, and blue states, respectively.

## 10. RELIABILITY

### 10.1 Test Condition

#### 10.1.1 Temperature and Humidity(Ambient Temperature)

Temperature :  $25 \pm 5^{\circ}\text{C}$

Humidity :  $65 \pm 5\%$

#### 10.1.2 Operation

Unless specified otherwise, test will be conducted under function state.

#### 10.1.3 Container

Unless specified otherwise, vibration test will be conducted to the product itself without putting it in a container.

#### 10.1.4 Test Frequency

In case of related to deterioration such as shock test. It will be conducted only once.

### 10.2 TESTS

No.	ITEM	CONDITION CRITERION
1	High Temperature Storage	80°C, 120 hrs
2	Low Temperature Storage	-30°C, 120 hrs
3	High Temperature Operating	70°C, 120 hrs
4	Low Temperature Operating	-20°C, 120 hrs
5	High Temperature/Humidity Non-Operating	60°C, 90%RH, 120 hrs
6	Temperature Shock Non-Operating	-30°C $\leftrightarrow$ 80°C (0.5hr each), 25 cycles
7	Vibration Test Non-Operating	Frequency:0 ~ 55 Hz Amplitude:1.5 mm Sweep Time:11min Test Period:6 Cycles for each Direction of X,Y,Z
8	Electro-static Discharge Non-Operating	150pF,330Ω Air:± 8KV;Contact: ±4KV 10 times/point;4 points/panel face

Note1: The test sample have recovery time for 24 hours at room temperature before the function check. In the standard conditions, there is no any touch panel function NG issue occurred.

5/18/2021

Page 27 of 32

### **10.3 JUDGMENT STANDARD**

The judgment of the above test should be made as follow:

Pass: Normal display image with no obvious non-uniformity and no line defect. Partial transformation of the module parts should be ignored.

Fail: No display image, obvious non-uniformity, or line defects.

### 10.4 INCOMING INSPECTION STANDARDS

No.	Parameter	Criteria										
1	Operating	Display function: No Display malfunction (Major)										
		Contrast ratio (Black, White): Does not meet specified range in the spec. (Major) (Note:3)										
		Line Defect: No obvious Vertical and Horizontal line defect in bright, dark and colored. (Major) (Note:1)										
		Point Defect : Active area $\leq 5$ dots (Minor) (Note:1)										
		<table border="1"> <thead> <tr> <th rowspan="2">Item</th> <th>Acceptable number</th> <th rowspan="2">Total</th> </tr> <tr> <th>Active Area</th> </tr> </thead> <tbody> <tr> <td>Bright</td> <td>2</td> <td rowspan="2">5</td> </tr> <tr> <td>Dark</td> <td>4</td> </tr> </tbody> </table>	Item	Acceptable number	Total	Active Area	Bright	2	5	Dark	4	
		Item		Acceptable number		Total						
Active Area												
Bright	2	5										
Dark	4											
Non-uniformity: Visible through 5%ND filter. (Minor)												
Foreign material in Black or White spots shape ( $W > 1/4L$ )												
<table border="1"> <thead> <tr> <th>Zone Dimension</th> <th>Acceptable number</th> <th rowspan="3">Class Of Defects</th> <th rowspan="3">AQL Level</th> </tr> </thead> <tbody> <tr> <td><math>D &gt; 0.5</math></td> <td>0</td> </tr> <tr> <td><math>0.3 &lt; D \leq 0.5</math></td> <td>5</td> </tr> <tr> <td><math>D \leq 0.3</math></td> <td>*</td> <td>Minor</td> <td>1.5</td> </tr> </tbody> </table> <p><math>D = (\text{Long} + \text{Short}) / 2</math> * : Disregard</p>	Zone Dimension	Acceptable number	Class Of Defects	AQL Level	$D > 0.5$	0	$0.3 < D \leq 0.5$	5	$D \leq 0.3$	*	Minor	1.5
Zone Dimension	Acceptable number	Class Of Defects			AQL Level							
$D > 0.5$	0											
$0.3 < D \leq 0.5$	5											
$D \leq 0.3$	*	Minor	1.5									
Foreign Material in Line or spiral shape ( $W \leq 1/4L$ ) (Note: 4)												
<table border="1"> <thead> <tr> <th>Zone L (mm) \ W(mm)</th> <th>Acceptable number</th> <th rowspan="3">Class Of Defects</th> <th rowspan="3">AQL Level</th> </tr> </thead> <tbody> <tr> <td><math>L &gt; 5</math>    <math>W &gt; 0.1</math></td> <td>0</td> </tr> <tr> <td><math>0.5 &lt; L \leq 5</math>    <math>0.03 &lt; W \leq 0.1</math></td> <td>5</td> </tr> <tr> <td><math>L \leq 0.5</math>    <math>W \leq 0.03</math></td> <td>*</td> <td>Minor</td> <td>1.5</td> </tr> </tbody> </table> <p>L : Length    W : Width    * : Disregard</p>	Zone L (mm) \ W(mm)	Acceptable number	Class Of Defects	AQL Level	$L > 5$ $W > 0.1$	0	$0.5 < L \leq 5$ $0.03 < W \leq 0.1$	5	$L \leq 0.5$ $W \leq 0.03$	*	Minor	1.5
Zone L (mm) \ W(mm)	Acceptable number	Class Of Defects			AQL Level							
$L > 5$ $W > 0.1$	0											
$0.5 < L \leq 5$ $0.03 < W \leq 0.1$	5											
$L \leq 0.5$ $W \leq 0.03$	*	Minor	1.5									
2	External Inspection (non-operating)	Dimension: Outline (Major)										
		Bezel appearance: uneven (Minor)										
		Scratch on the polarize: (Note:2)										
		<table border="1"> <thead> <tr> <th>Zone L (mm) \ W(mm)</th> <th>Acceptable number</th> <th rowspan="2">Class Of Defects</th> <th rowspan="2">AQL Level</th> </tr> </thead> <tbody> <tr> <td>--    <math>W &gt; 0.1</math></td> <td>0</td> </tr> <tr> <td><math>L \leq 3</math>    <math>W \leq 0.1</math></td> <td>3</td> <td>Minor</td> <td>1.5</td> </tr> </tbody> </table> <p>L : Length    W : Width    * : Disregard</p>	Zone L (mm) \ W(mm)	Acceptable number	Class Of Defects	AQL Level	-- $W > 0.1$	0	$L \leq 3$ $W \leq 0.1$	3	Minor	1.5
		Zone L (mm) \ W(mm)	Acceptable number	Class Of Defects			AQL Level					
-- $W > 0.1$	0											
$L \leq 3$ $W \leq 0.1$	3	Minor	1.5									
Dent or bubble on the polarize (Note:2)												
<table border="1"> <thead> <tr> <th>Zone Dimension</th> <th>Acceptable number</th> <th rowspan="2">Class Of Defects</th> <th rowspan="2">AQL Level</th> </tr> </thead> <tbody> <tr> <td><math>D \leq 0.3</math></td> <td>*</td> </tr> <tr> <td><math>D \leq 0.5</math></td> <td>3</td> <td>Minor</td> <td>1.5</td> </tr> </tbody> </table> <p><math>D = (\text{Long} + \text{Short}) / 2</math> * : Disregard</p>	Zone Dimension	Acceptable number	Class Of Defects	AQL Level	$D \leq 0.3$	*	$D \leq 0.5$	3	Minor	1.5		
Zone Dimension	Acceptable number	Class Of Defects			AQL Level							
$D \leq 0.3$	*											
$D \leq 0.5$	3	Minor	1.5									

Class of defects			<b>Definition</b>
	<b>Major</b>	AQL 0.65%	It is a defect that is likely to result in failure or to reduce materially the usability of the product for the intended function.
<b>Minor</b>	AQL 1.5%	It is a defect that will not result in functioning problem with deviation classified.	

**Note1:**

- (a) Bright point defect is defined as point defect of R,G,B with area  $>1/2$  pixel respectively
- (b) Dark point defect is defined as visible in full white pattern.
- (c) Definition of distribution of point defect is as follows:
  - minimum separation between dark point defects should be larger than 5mm.
  - minimum separation between bright point defects should be larger than 5mm.
- (d) Definition of joined bright point defect and joined dark point defect are as follows:
  - Two or more joined bright point defects must be nil.
  - Three joined dark point defects must be nil.
  - Coupling of one dark and one bright point in junction is counted as one dark and bright spot with 1 pair maximum.
  - Two Joined dark point is counted as two dark points with 2 pair maximum.

**Note2:** The external inspection should be conducted at the distance  $30 \pm 5$ cm between the eyes of inspector and the panel.

**Note3:** Luminance measurement for contrast ratio is at the distance  $50 \pm 5$ cm between the detective head and the panel with ambient luminance less than 1 lux. Contrast ratio is obtained at optimum view angle.

**Note4:** W-Width in mm , L-length of Max.(L1,L2) in mm.

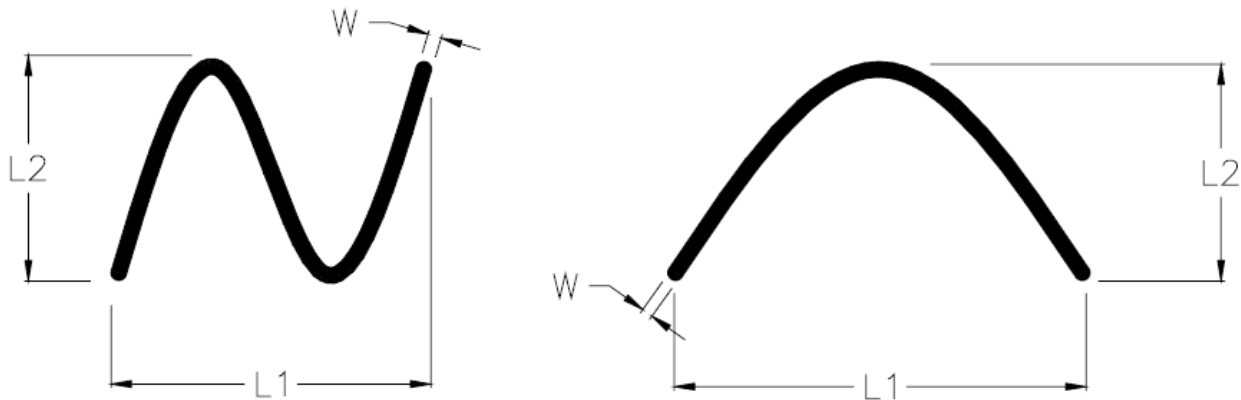

### 10.5 Sampling Condition

Unless otherwise agree in written, the sampling inspection shall be applied to the incoming inspection of customer.

Lot size: Quantity of shipment lot per model.

Sampling type: normal inspection, single sampling

Sampling table: MIL-STD-105E

Inspection level: Level II

### 10.6 Inspection conditions

The LCD shall be inspected under 40W white fluorescent light.

$\theta \leq 45^\circ$  inspection under non-operating condition.

$\theta \leq 5^\circ$  inspection under operating condition

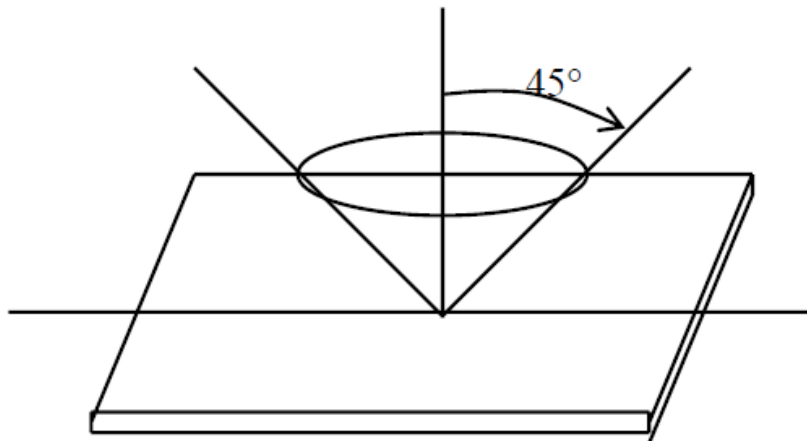

## **11. PRECAUTION RELATING PRODUCT HANDLING**

### **11.1 SAFETY**

**11.1.1** If the LCD panel breaks , be careful not to get the liquid crystal to touch your skin.

**11.1.2** If the liquid crystal touches your skin or clothes , please wash it off immediately by using soap and water.

### **11.2 HANDLING**

**11.2.1** Avoid any strong mechanical shock which can break the glass.

**11.2.2** Avoid static electricity which can damage the CMOS LSI—When working with the module, be sure to ground your body and any electrical equipment you may be using.

**11.2.3** Do not remove the panel or frame from the module.

**11.2.4** The polarizing plate of the display is very fragile. So , please handle it very carefully, Do not touch, push or rub the exposed polarizing with anything harder than an HB pencil lead (glass , tweezers , etc.)

**11.2.5** Do not wipe the polarizing plate with a dry cloth, as it may easily scratch the surface of plate.

**11.2.6** Do not touch the display area with bare hands , this will stain the display area.

**11.2.7** Do not use ketonics solvent & aromatic solvent. Use with a soft cloth soaked with a cleaning naphtha solvent.

**11.2.8** To control temperature and time of soldering is  $280 \pm 10^{\circ}\text{C}$  and 3-5 sec.

**11.2.9** To avoid liquid (include organic solvent) stained on LCM.

### **11.3 STORAGE**

**11.3.1** Store the panel or module in a dark place where the temperature is  $25^{\circ}\text{C} \pm 5^{\circ}\text{C}$  and the humidity is below 65% RH.

**11.3.2** Do not place the module near organics solvents or corrosive gases.

**11.3.3** Do not crush, shake, or jolt the module.